

The Importance of Helical Pile Coupler Details

Jeff Kortan, P.E. Director of Engineering

The coupler detail is an important feature when considering helical piles and when selecting or specifying a product manufacturer. Manufacturers may advertise that they carry the same or equivalent helical shaft. However, shaft and coupler details are not consistent between manufacturers and these differences may not be readily apparent by simply reviewing product capacity tables. Some manufacturers rate their products based upon the capacities of the gross section of the shaft, thereby ignoring any limitations caused by the coupled connections. For these “equivalent” products, there can be dramatic differences in material properties, tolerances, spacing of bolt holes, oversize of bolt holes, general fit-up, weld quality, etc.

Figure 1: FSI External Welded Coupler



Figure 2: FSI External Detached Coupler

Some of the more common coupler details for round shaft include external welded, external detached, internal detached, and forged and upset. External couplers utilize tube or pipe sections with an internal diameter slightly larger than the outside diameter of the central shaft material (See Figures 1 and 2). These couplers can be sized to provide tight connections that reduce angular deformation and variances from straightness. Such displacements at the couplers introduce eccentricities to the system which can significantly reduce the allowable compressive capacity of the pile, especially considering the slenderness of the more widely used shaft material (typically 3.5-inch outside diameter and smaller).

Internal detached couplers are made from solid round stock or tube or pipe material but with an outside diameter smaller than the inside diameter of the central shaft material. Internal coupler diameters may be significantly undersized to prevent interferences with internal weld beads of the central shaft or

due to the variations that are typical in wall thicknesses and inside diameters of pipe sections. Larger gaps between the inside diameter of the shaft and the outside diameter of the coupler can result in a connection with more potential for angular displacements.

Figure 3: Upset Coupler With Over-Sized, Closely-Spaced Bolt Holes



Forged and upset couplers are formed by heating one end of the shaft, placing this end in a form and then enlarging the end with a hammer-like tool or press (See Figure 3). With this method of manufacturing, it is difficult to create tight connections to strict tolerances. It is not uncommon to have 1/8-inch or more difference between the outside diameter of the shaft and the inside diameter of the upset coupler of the round shaft (See Figure 4). Again, the greater the freedom allowed in the connection, the greater the potential variance from straightness and the higher the potential for bending or buckling of the pile

Figure 4: Coupler Tolerances
(A) Competitor Upset Coupler, (B) FSI External Welded Coupler

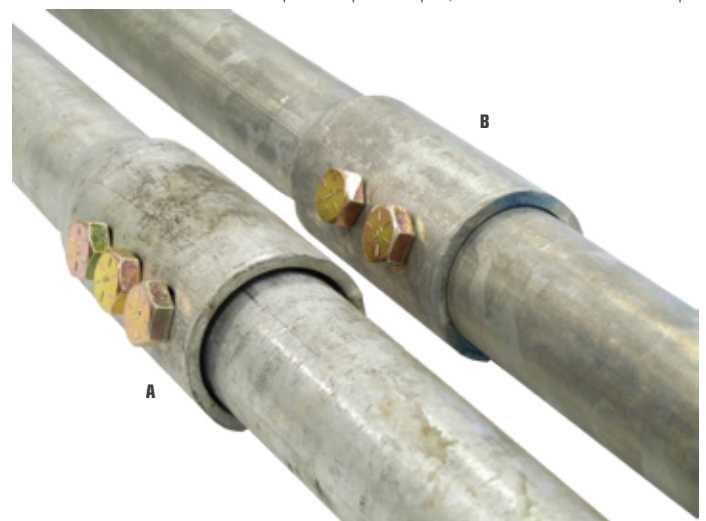

Figure 5: Competitor Upset Coupler, Variance from Straightness



under high compressive loads (See Figure 5). The risk of pile buckling further increases with unsupported lengths above the ground surface, or if the pile extends through soil strata consisting of soft clays or very loose sand.

FSI round shaft helical piles are manufactured with external welded or detached couplers. These systems are manufactured to strict tolerances to allow the pile shafts to be in direct contact inside the coupler, similar to Figure 6. Why is this important? The load path for piles under compression is then directly through

Figure 6

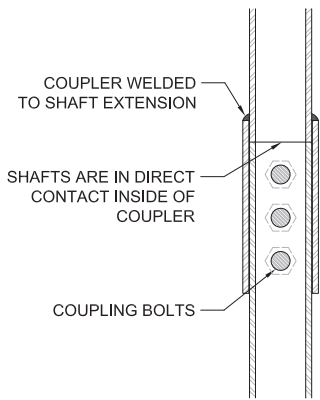

Figure 7: FSI External Detached Coupler



Figure 8: FSI External Welded Coupler

the shafts of the extensions and lead section without having to pass through welds and bolts at each connection. The annular space between the pile shaft and coupler is also kept as tight as practical to maintain pile rigidity while also providing connections that are easily joined in the field (See Figures 7 and 8).

The most common coupler detail for solid square shaft utilizes a forged and upset end (See Figure 9). Cast detached couplers have also been used in lieu of the upsetting process. The upset end of square shaft is created in a similar manner as for the round shaft, except for forming a square socket connection.

Figure 9

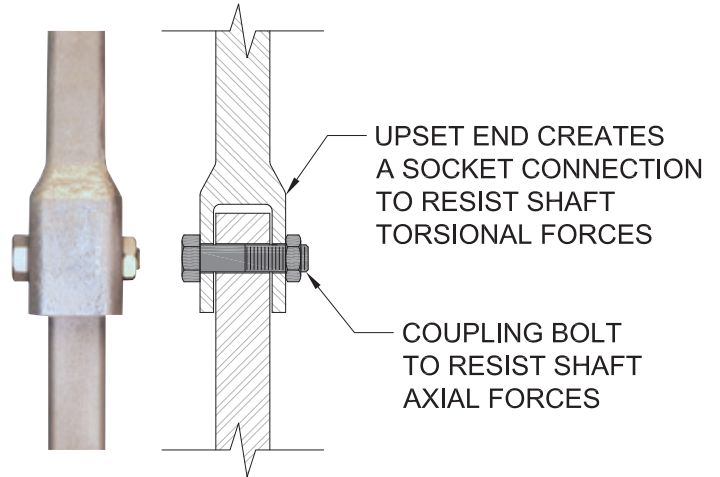

Figure 10 clearly shows a comparison of coupling rigidity between an FSI external welded coupler for round shaft and a typical upset coupler for square shaft. A similar draping effect is typical for round shaft helical piles with upset couplers.

As you now know, there are obvious, significant differences in coupling details that differentiate otherwise "like" products. FSI recommends that the design engineer request product drawings and review coupling details, tolerances and general fit-up prior to product selection. Please contact FSI with any of your product or application questions.

Figure 10: (A) Round, (B) Square



Jeff Kortan, P.E. Director of Engineering

Jeff is involved in product design, product verification testing, preliminary design applications, project consulting, conducting installation, sales and marketing training, as well as developing and presenting education-based material. Jeff routinely travels throughout the United States and Canada to consult with local installing contractors about general or project-specific needs, and to present technical information to engineers, architects and general contractors.